

Espay Solar Energy S.L.

Ex-factory price of 30kWh power storage cabinet for residential use



Overview

A 30 kWh household energy storage cabinet costs between \$12k and \$25k, but smart choices—like modular designs and incentive stacking—can maximize savings. As battery tech evolves, prices will keep falling, making energy independence accessible to more homes. Please enter your name, email, and phone number below. We will contact you as soon as this product is available. [Click here for User Manual details.](#) Commercial and Industrial Backup Power: Businesses and. HBOWA PV energy storage systems offer multiple power and capacity options, with standard models available in 20KW 50KWh, 30KW 60KWh, and 50KW 107KWh configurations. Featuring LiFePO4 cells, it provides reliable capacity and fits in standard 19-inch racks. With over 6000 charge cycles at 80% DOD, it ensures long-term durability.

Ex-factory price of 30kWh power storage cabinet for residential use

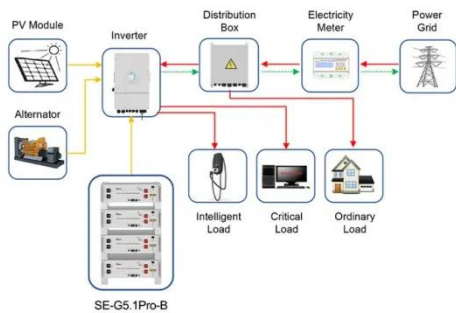

Application scenarios of energy storage battery products

What is the price of factory energy storage cabinet?

In conclusion, comprehensively understanding the price of factory energy storage cabinets reveals a multifaceted landscape driven by technology, capacity, installation and ...

LV-Rack-30KWh Cabinet type battery energy storage cabinet

Cost: Initial setup costs can be significant, although the modularity and scalability can result in long-term savings, especially as the cost of battery technology continues to decrease.



How to Choose the Best 30kWh Energy Storage System: A ...

Discover what to look for in a 30kWh energy storage system, including key specs, top models, and expert tips for making the right choice.



Outdoor 30 KWh Heated/Cooled Weathertight ...

Home Complete Rack Mounted Systems
Outdoor 30 KWh Heated/Cooled
Weathertight Enclosure Lithium Storage
with 12KW Hybrid Inverter



What's the Price of a Household Energy Storage Cabinet? Your 2025

...

Maybe you're tired of unpredictable utility bills, or perhaps you're just curious about jumping on the "virtual power plant" bandwagon (more on that later). Either way, you want clear ...

10kWh to 30kWh Rack Battery Cabinet , Dagong ESS

The 10kWh to 30kWh Rack Battery Cabinet is a compact, scalable energy storage solution for residential and commercial use. Featuring LiFePO4 cells, it provides reliable capacity and fits in ...



How Much Does a 30 kWh Household Energy Storage Cabinet Cost?

Understanding the 30 kWh Household Energy Storage Market Home energy



storage systems, like 30 kWh cabinets, are becoming essential for homeowners seeking energy independence. Think of them ...

Energy Storage Cabinet Outdoor 20KW 50KWh/ 30KW 60KWh

HBOWA is an experienced energy storage battery manufacturer, our energy storage systems are competitive with the factory price, and OEM and ODM services are available.



30KWh Modular Energy Storage Cabinet

30KWh Modular Energy Storage Cabinet
- Source Factory Custom Capacity Plug & Play Easy Install

30kWh Enphase Ensemble Package

Shop our 30kWh Enphase Ensemble battery backup package to add an energy storage solution to your solar power system.

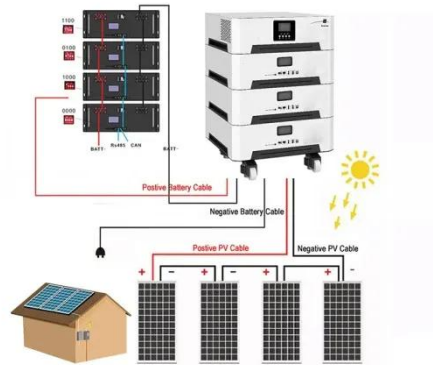

Contact Us

For catalog requests, pricing, or partnerships, please visit:
<https://espay.es>

